

NPA

Yeni Ürün Duyurusu No. 2019-30



CHASE 10 MILL

FACE MILLING

**Ekonomik, 10 Kesme Kenarlı Uç
Bağlayan Yüksek İlerleme ve
Yüzey Frezeleme Ürün Ailesi**



ÖNEMLİ NOKTALAR

TaeguTec, PTKU 05 ve 10 kesici uçlu yeni bir yüksek ilerleme ve yüzey frezeleme ürün ailesini çıkardı.

TaeguTec, yüksek ilerleme talebine cevap vermek için ekonomik çok köşeli **CHASE-10-MILL PTKU** uç ailesini piyasaya sürdü.

PTKU uçları, özellikle yüksek ilerlemeli işlemler için geliştirilmiş çift taraflı, on kesme kenarlı ürün ailesidir. İki boyutta mevcut: 05 mm. ve 10 mm. ; yeni kesici uçlar sırasıyla 1.5 mm. ve 3.0 mm. maksimum kesme derinliğine sahiptir. PTKU uçlar, kalıpcılık ve genel mühendislik uygulamalarını içeren geniş bir endüstriyel alana hitap eder.

PTKU uçları, 65° giriş açısına sahip yüzey frezeleme ile birlikte yüksek ilerlemeli işlemler için de kullanılabilir. Bu 65° giriş açısı, 45°'lik mükemmel kesim ve 75°'lik büyük işleme derinliği avantajlarını bir araya getirir. Yüzey frezeleme takımları maksimum 3.3 mm. ve 6.5 mm. kesme derinliğine kadar kullanılabilir.

Daha fazla teknik sorularınız için, lütfen TaeguTec Ürün Müdürleri ile iletişime geçiniz.

Özellikler

- Çift taraflı 10 kesme kenarlı uç
 - güçlendirilmiş kesme kenarları
 - pozitif talaş yüzeyi
- Aynı kesici uç hem yüksek ilerlemeli frezeleme hem de yüzey frezeleme uygulamalarını yapabilir.

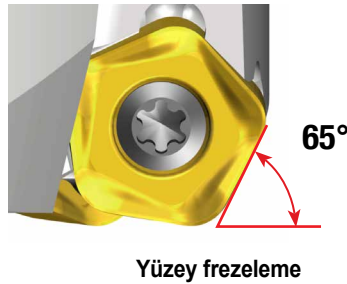
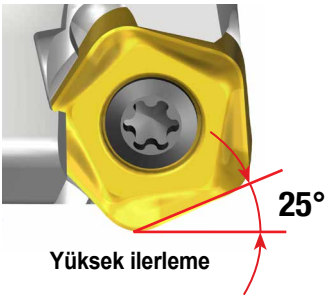

- Derin cep boşaltmalarında düşük kesme kuvveti (Yüksek ilerleme)

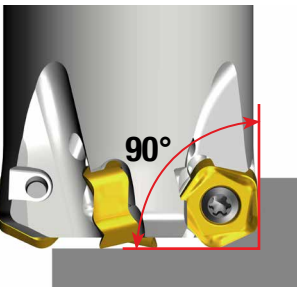

- Pürüzsüz işleme için yüksek pozitif talaş açısı (Yüksek ilerleme)

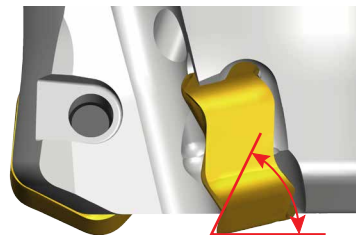

■ Önerilen Uygulamalar

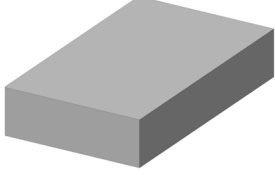

(◎)

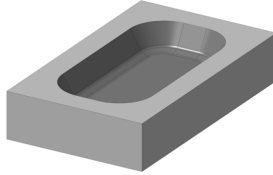

(◎)

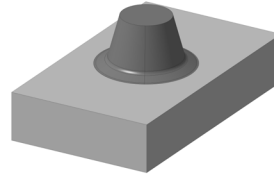

(◎)

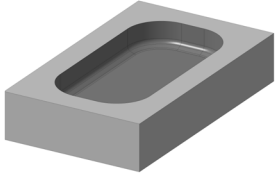

(○)

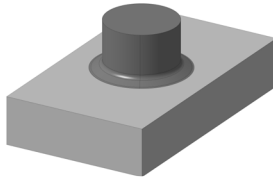

(○)

◎ : Önerilen

○ : İsteğe bağlı



Uygunluk

Stokta

Fiyat

GAL sistemi üzerinden
ulaşılabilir

Saygılarımla,
TaeguTec

Cho Yeo-myeong

Dönen Takımlar Genel Ürün Müdürü

Saygılarımla,
TaeguTec

Lee Jae-wook

Frezeleme Ürün Müdürü

Örnek çalışma 1

		Rakip	TaeguTec
Malzeme		Takım çeliği (DIN 1.2344)	
Kesici		Ø32, 2z	TEPT 532-32-05 (Ø32, 5z)
Uç		SXXX 12	PTKU 0503R-M TT9080
Kesme hızı	V (m/dk)	180	120
İlerleme	f (mm/dış)	0.6	0.6
	F (mm/dk)	2150	3583
Kesme derinliği	ap (mm)	1	1
Kesme genişliği	ae (mm)	22	22
MRR (cm ³ /min)		47	80
Tool life (pcs/corner)		2	3

MRR (cm³/dk)

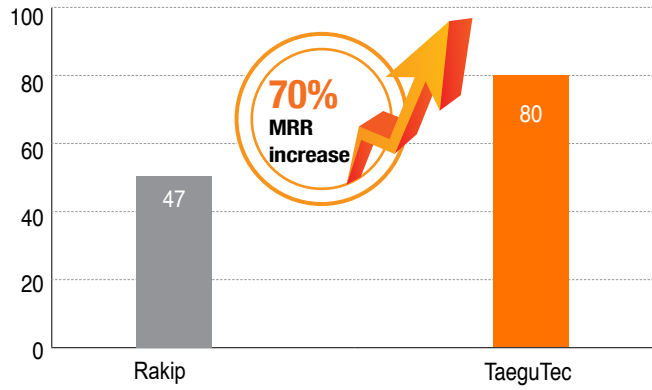

Takım ömrü (pcs/corner)

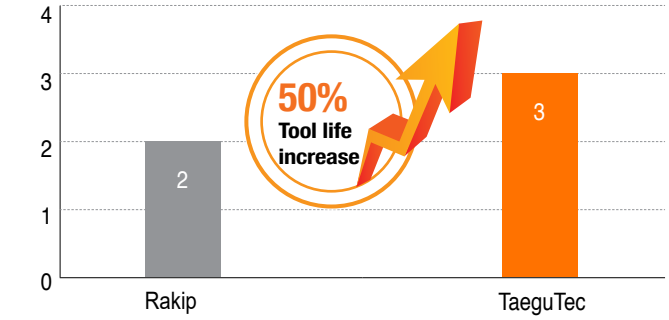

Örnek çalışma 2

		Rakip	TaeguTec
Malzeme		Paslanmaz çelik (AISI 304)	
Kesici		Ø80, 6z	TFM65PT 680-27R-10 (Ø80, 6z)
Uç		BXXX 12	PTKU 1006R-M TT8080
Kesme hızı	V (m/dk)	120	120
İlerme	f (mm/dış)	0.1	0.15
	F (mm/dk)	287	430
Kesme derinliği	ap (mm)	3	3
Kesme genişliği	ae (mm)	55	55
MRR (cm ³ /dk)		48	72

MRR (cm³/dk)

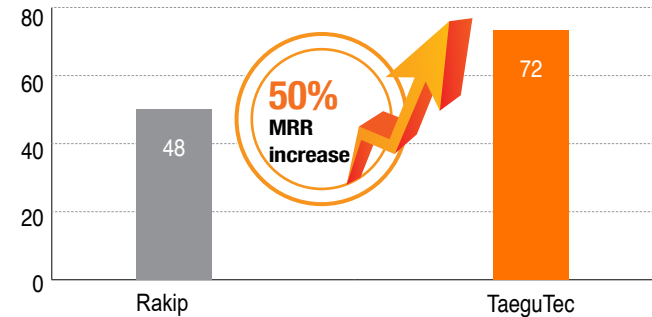

TFMPT-05



Yüksek ilerlemeye uygun yüzey frezeleme takımları

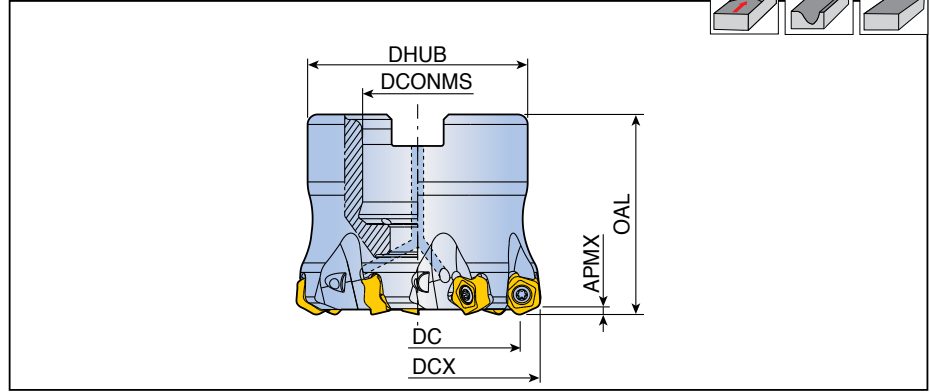
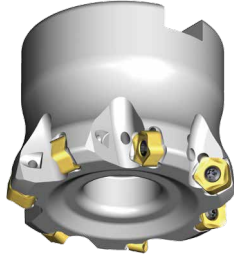

Kodlama	Z	Ölçü (mm)						Soğutma	Arbor tipi	Kg	Bağlantı civatası	Uç
		DCX	DC	DCONMS	DHUB	OAL	APMX					
TFMPT 640-16R-05	6	40	31.8	16	38	40	1.5	•	A	0.3	SH M8x25	PTKU 0503...
750-22R-05	7	50	41.8	22	45	40	1.5	•	A	0.4	LH M10x25	
752-22R-05	7	52	43.8	22	45	40	1.5	•	A	0.3	LH M10x25	
863-22R-05	8	63	54.8	22	58	50	1.5	•	A	0.8	SH M10x30	
866-27R-05	8	66	57.8	27	58	50	1.5	•	A	0.7	SH M12x35	

Yedek parçalar

Kodlama	Vida	Anahtar			
TFMPT-05	TS 25D060/HG-P	TD 7P			

TFM65PT-05

CHASE 10 MILL
FACE MILLING

Yüzey frezeler

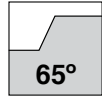
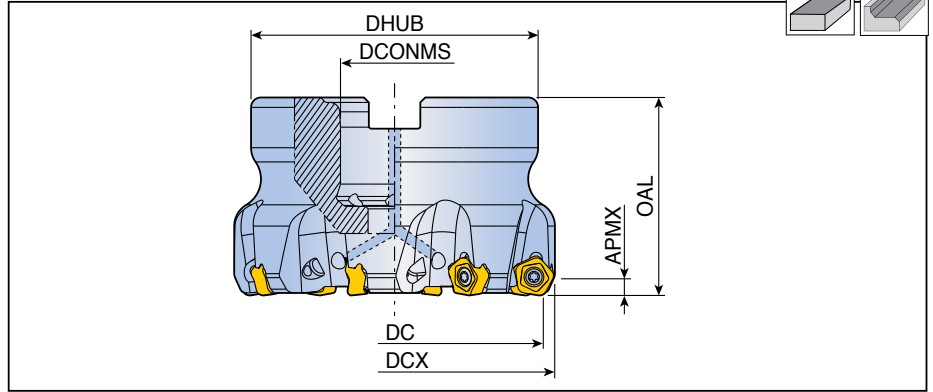
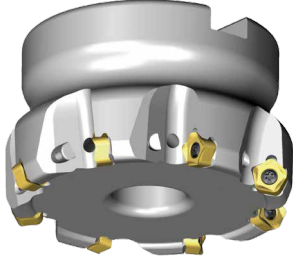

Kodlama	Ø	Ölçü (mm)						Soğutma	Arbor tipi	Kg	Bağlantı civatası	Uç
		DC	DCX	DCONMS	DHUB	OAL	APMX					
TFM65PT 640-16R-05	6	40	43.7	16	38	40	3.3	•	A	0.3	SH M8x25	PTKU 0503...
750-22R-05	7	50	53.7	22	45	40	3.3	•	A	0.4	SH M10x30	
863-22R-05	8	63	66.7	22	58	40	3.3	•	A	0.7	SH M10x30	

Yedek parçalar

Kodlama	Vida	Anahtar			
	TFM65PT-05	TS 25D060/HG-P	TD 7P		

TEPT-M-05

CHASE 10 MILL
FACE MILLING

T-FLEXTEC için yüksek ilerlemeye uygun modüler başlıklar

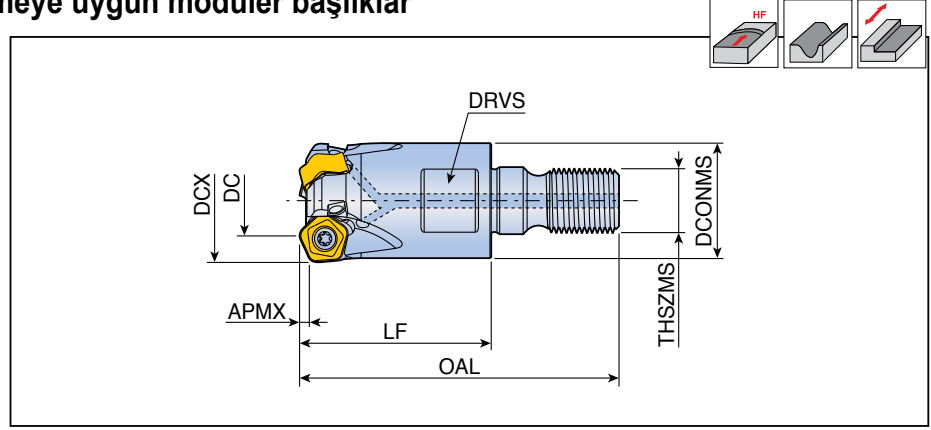

Kodlama	Ø	Ölçü (mm)								Soğutma	Uç
		DCX	DC	DCONMS	LF	OAL	THSZMS	APMX	DRVS		
TEPT 320-M10-05	3	20	11.9	18	30	50	M10	1.5	15	●	PTKU 0503...
425-M12-05	4	25	16.8	21	35	57	M12	1.5	17	●	
532-M16-05	5	32	23.8	29	43	68	M16	1.5	25	●	
640-M16-05	6	40	31.8	29	43	68	M16	1.5	25	●	

• T-FLEXTEC takım gövdeleri ile uyumludur.

Yedek parçalar

Kodlama	Vida	Anahtar			
	TEPT-05	TS 25D060/HG-P	TD 7P		

TFMPT-10

CHASE 10 MILL
FACE MILLING

Yüksek ilerlemeye uygun yüzey frezeler

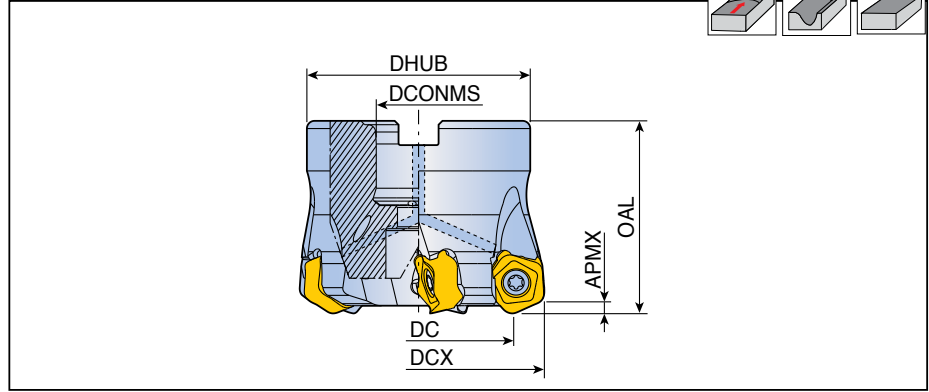

Kodlama	Ø	Ölçü (mm)						Soğutma	Arbor tipi	Kg	Bağlantı civatası	Uç
		DCX	DC	DCONMS	DHUB	OAL	APMX					
TFMPT 450-22R-10	4	50	33.4	22	45	40	3.0	•	E	0.3	TCS10-40	PTKU 1006...
563-22R-10	5	63	46.4	22	58	50	3.0	•	A	0.8	SH M10x30	
566-22R-10	5	66	49.4	22	58	50	3.0	•	A	0.8	SH M10x30	
680-27R-10	6	80	63.4	27	70	60	3.0	•	A	1.4	SH M12x30	
8100-32R-10	8	100	83.4	32	85	60	3.0	•	A	2.3	SH M16x35	
9125-32R-10	9	125	108.4	32	85	60	3.0	•	A	3.1	SH M16x35	
10160-40R-10	10	160	143.4	40	110	60	3.0	x	C	4.1	-	
12200-60R-10	12	200	183.4	60	130	60	3.0	x	C	5.7	-	

Yedek parçalar

Kodlama	Vida	Anahtar	Anahtar sapı		
TFMPT-10	TS 50D130/HG-P	TBLD T20P-W6	SW6-T		

TFM65PT-10

CHASE 10 MILL
FACE MILLING

Yüzey frezeler

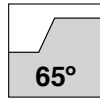
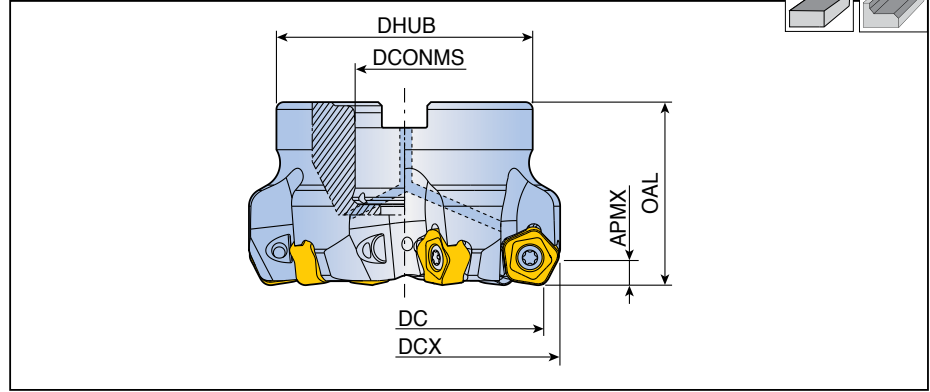
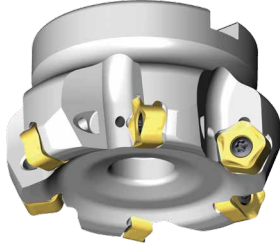

Kodlama	Ø	Ölçü (mm)						Soğutma	Arbor tipi	Kg	Bağlantı cıvatası	Uç
		DC	DCX	DCONMS	DHUB	OAL	APMX					
TFM65PT 680-27R-10	6	80	87.4	27	70	50	6.5	•	A	1.2	LH M12x30	PTKU 1006...
8100-32R-10	8	100	107.4	32	85	50	6.5	•	A	1.9	LH M16x35	
9125-40R-10	9	125	132.4	40	85	63	6.5	•	A	3.2	SH M20x40	

Yedek parçalar

Kodlama	Vida	Anahtar	Anhtar sapı		
TFM65PT-10	TS 50D130/HG-P	TBLD T20P-W6	SW6-T		

PTKU

CHASE 10 MILL
FACE MILLING

Uçlar

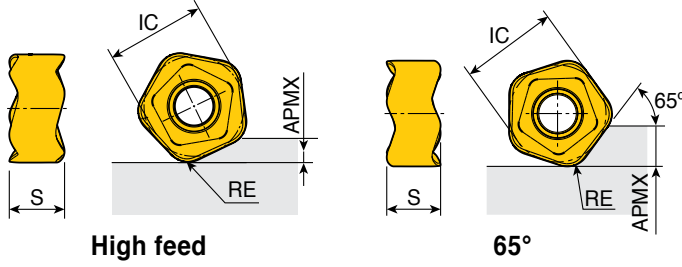

Boyut	Ölçü (mm)					
	IC	S	APMX	RE		
05(HF)	7.1	3.8	1.5	1.5		
05(65°)	7.1	3.8	3.3	1.5		
10(HF)	14.2	7.7	3.0	3.0		
10(65°)	14.2	7.7	6.5	3.0		

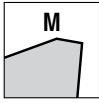

Uç	Kodlama	Önerilen işleme koşulları		Kaplama							Kaplamasız			
		ap (mm)	Feed (mm/tooth)	TT9080	TT9030	TT8080	TT8020	TT8525	TT7080	TT7515	TT6080		K10	
	PTKU 0503R-M (High feed)	0.2-1.5	1.20-0.20	●		●								
	1006R-M (High feed)	0.3-2.0	2.00-0.30	●		●								
	PTKU 0503R-M (65°)	1.0-3.0	0.20-0.07	●		●								
	1006R-M (65°)	1.5-5.0	0.25-0.10	●		●								

●: Standart ürünler

Rampalama bilgisi

CHASE 10 MILL
FACE MILLING

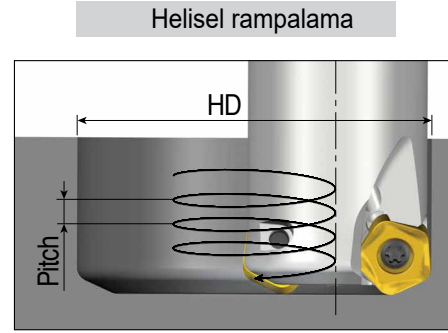
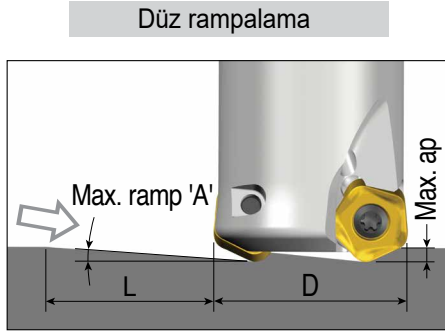

PTKU 05

(unit: mm)

Kesme çapı(D)	Aşağı doğru düz rampalama			Aşağı doğru helisel rampalama			
	Mak. ramp (A°)	Mak. ap	Min. uzunluk (L)	Min. çap (HD)	Mak. çap (HD)	Mak. hatve/dev.	
Ø20	1.3	1.5	66	33	40	0.7	
Ø25	1.1		78	43	50	0.8	
Ø26	1.0		86	45	52	0.8	
Ø32	1.0		86	57	64	1.0	
Ø33	1.0		86	59	66	1.0	
Ø40	0.8		101	73	80	1.1	
Ø50	0.7		123	93	100	1.2	
Ø52	0.7		123	97	104	1.2	
Ø63	0.6		132	119	126	1.3	
Ø66	0.6		143	125	132	1.3	
						1.4	

Programlama teknik bilgisi

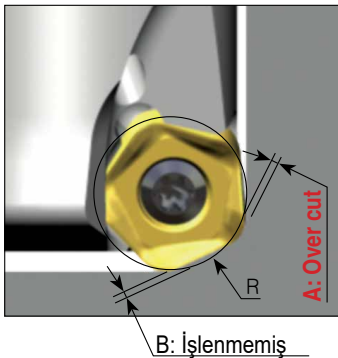

	R Program	A Fazla kesim	B İşlenmemiş
PTKU 05	2.5	0.00	0.83
	2.7	0.00	0.76
	3.0	0.04	0.66

■ : Önerilen program 'R'

Ramping Data



Düz rampalama

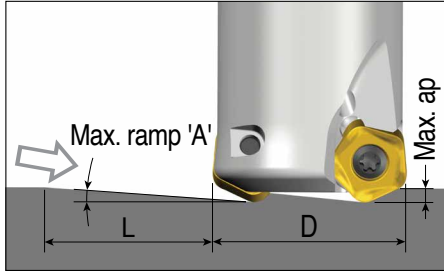

Helisel rampalama

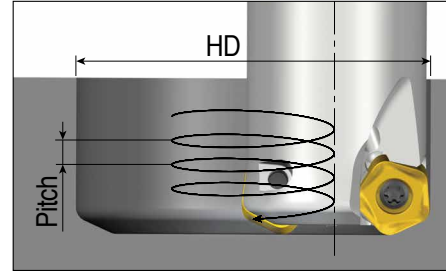

PTKU 10

(unit: mm)

	Aşağı doğru düz rampalama			Aşağı doğru helisel rampalama		
	Mak. ramp (A°)	Mak. ap	Min. uzunluk (L)	Min. çap (HD)	Mak. çap (HD)	Mak. hatve/dev.
Ø40	1.5	3.0	111	63	80	1.7
Ø50	1.9		88	83	100	2.8
Ø63	1.7		101	109	126	3.0
Ø66	2.2		78	115	132	3.0
Ø80	1.5		115	143	160	3.0
Ø100	1.1		150	183	200	3.0
Ø125	0.8		202	233	250	3.0
Ø160	0.6		265	303	320	3.0
Ø200	0.5		344	383	400	3.0

Programlama teknik bilgisi

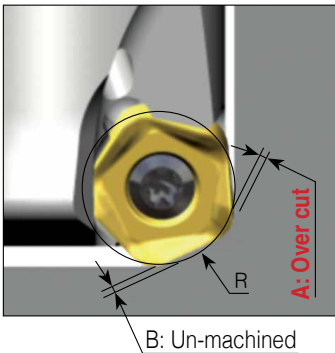

	R Program	A Fazla kesim	B İşlenmemiş
PTKU 10	5.5	0.00	1.45
	6.0	0.09	1.28
	6.5	0.21	1.11

■ : Önerilen program 'R'

KIT COLLECTIONS

Bu kit ürünleri aşağıda listelenen içerikte mevcuttur.



Kat. No.	Kodlama	Ürün Ağacı	Miktar
6334782	KISFT-TEPT 425-25-05-L150	TEPT 425-25-05-L150	1
		PTKU 0503R-M TT9080	8
6334783	KISFT-TEPT 532-32-05-L200	TEPT 532-32-05-L200	1
		PTKU 0503R-M TT9080	10
6334784	KISFT-TEPT 640-32-05-L200	TEPT 640-32-05-L200	1
		PTKU 0503R-M TT9080	12
6334785	KISFT-TFMPT 750-22R-05	TFMPT 750-22R-05	1
		PTKU 0503R-M TT9080	14
6334786	KISFT-TFMPT 450-22R-10	TFMPT 450-22R-10	1
		PTKU 1006R-M TT9080	8
6334787	KISFT-TFMPT 563-22R-10	TFMPT 563-22R-10	1
		PTKU 1006R-M TT9080	10
6334788	KISFT-TFMPT 680-27R-10	TFMPT 680-27R-10	1
		PTKU 1006R-M TT9080	12



Kat. No.	Kodlama	Ürün Ağacı	Miktar
6337848	KISFS-TEPT 425-25-05-L150	TEPT 425-25-05-L150	1
		PTKU 0503R-M TT9080	50
6337849	KISFS-TEPT 532-32-05-L200	TEPT 532-32-05-L200	1
		PTKU 0503R-M TT9080	50
6337850	KISFS-TEPT 640-32-05-L200	TEPT 640-32-05-L200	1
		PTKU 0503R-M TT9080	50
6337851	KISFS-TFMPT 750-22R-05	TFMPT 750-22R-05	1
		PTKU 0503R-M TT9080	50
6337853	KISFS-TFMPT 450-22R-10	TFMPT 450-22R-10	1
		PTKU 1006R-M TT9080	50
6337854	KISFS-TFMPT 563-22R-10	TFMPT 563-22R-10	1
		PTKU 1006R-M TT9080	50
6337855	KISFS-TFMPT 680-27R-10	TFMPT 680-27R-10	1
		PTKU 1006R-M TT9080	50



Kat. No.	Kodlama	Ürün Ağacı	Miktar
6338427	KISFF-A-PTKU 05-M TT9080	PTKU 0503R-M TT9080	100
6338428	KISFF-B-PTKU 05-M TT9080		300
6338429	KISFF-A-PTKU 10-M TT9080	PTKU 1006R-M TT9080	100
6338430	KISFF-B-PTKU 10-M TT9080		300